

OWNERS MANUAL

Jet Sprinkler Pump



SAFETY WARNINGS



BEFORE OPERATING OR INSTALLING THIS PUMP, READ THIS MANUAL AND FOLLOW ALL SAFETY RULES AND OPERATING INSTRUCTIONS.

WARNING - ELECTRICAL PRECAUTIONS

All wiring, electrical connections, and system grounding must comply with the National Electrical Code (NEC) and with any local codes and ordinances. Employ a licensed electrician.

WARNING FOR DUAL VOLTAGE MOTORS:

Voltage change instructions are located on motor label or on wiring access cover.

WARNING - RISK OF ELECTRICAL SHOCK

- This pump is supplied with a grounding conductor and grounding type attachment plug.
- To reduce risk of electrical shock, be certain that it is connected only to a properly grounded, grounding-type receptacle.

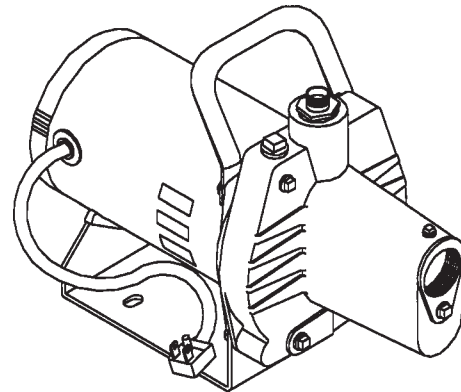

- A ground fault interrupter (GFI) protected circuit is recommended for use with any electrical device operating near water.
- Have an electrician provide an outlet near the point of use. For recommended cable size see table 1.
- Pump and motor must be protected from the weather, for indoor use only.
- Motor must be grounded and terminal cover in place to reduce electrical shock hazard.
- Keep motor operating area as dry as possible.
- Always disconnect power before servicing.
- Not investigated for use in swimming pool area.

APPLICATION

This jet sprinkler pump is a versatile pump for pressure boosting: small underground sprinkler systems: operating lawn sprinklers and a multitude of other general purpose applications. This pump is suitable for installations where the vertical distance from the pump

to the water level does not exceed *25 ft. (7.6m), including drawdown. In offset installations, friction losses in the suction pipe must be taken into consideration. (Refer to Table 2, Friction loss Chart).

*Less at high altitudes.

PERFORMANCE

Pump H.P.	Discharge Pressure	U.S. Gallons per minute, at static lift in feet below					Litres per minute, at static lift in meters below				
		5' lift	10' lift	15' lift	20' lift	25' lift	1.5 lift	3.0 lift	4.5 lift	6.0 lift	7.5 lift
1/2	40	11.2	10.4	9.4	7.6	5.3	42.4	39.4	35.6	28.8	20.1

INSTALLATION

- Pump Location:** The pump should be installed in a clean, dry and ventilated location which provides adequate room for servicing and protection from freezing temperatures. It should be bolted to a good foundation, preferably concrete and provided adequate drainage. Locating the pump as close as possible to the water source reduces the friction in the suction pipe and will give maximum capacities.
- Suction pipe:** It is recommended that only new, clean 1-1/4 inch pipe or hose be used. If the pump is installed any appreciable distance away from the source of water, the suction pipe should be increased to 1-1/2 inch. Horizontal lengths of pipe must gradually slope upwards from the source of water to the pump to avoid air pockets in the line. Thread compound should be used on all pipe joints and connections should be thoroughly tightened. A foot valve must be installed and its operation should be checked since a leak will prevent proper operation of the system. Make sure that the foot valve is located so that it will be submerged at all times. If a sand point or driven well is used, install a check valve next to the pump suction instead of the foot valve. For booster pump applications no foot valve is required.
- Service Line:** The service line should be connected as shown in Fig. 1. The size of the service line required is governed entirely by the amount of water needed and the length of the pipe. The pipe selected should be large enough so that the friction loss (determined from Table 2, Friction Loss Chart) will never exceed a 20 ft. (6m) head.

CAUTION

Undersize wire between the motor and the power source will adversely limit the starting and load carrying abilities of the motor. Minimum wire sizes for the motor branch circuits are recommended in table 1.

TABLE 1

Recommended Wire Gauge For Electrical Cord Length						
HP	Volts	0-25 ft.	50ft.	100ft.	150ft.	200ft.
1/2	115	14	12	10	8	6

TABLE 2- FRICTION LOSS CHART FOR PLASTIC PIPE:

For galvanized pipe, double the figures.
Loss of head in feet, due to friction per 100 feet of pipe.

Nominal Pipe Size U.S. GPM	3/4"	1"	1-1/4"	1-1/2"	2"
4	3.75	1.15	.30	.14	-
5	5.66	1.75	.46	.22	-
6	7.95	2.45	.65	.31	-
7	10.6	3.25	.86	.41	-
8	13.5	4.16	1.10	.52	-
9	16.8	5.17	1.35	.65	-
10	20.4	6.31	1.67	.79	.23
11	24.4	7.58	1.98	.95	.27
12	28.6	8.85	2.33	1.10	.32
14	38.0	11.8	3.10	1.46	.43
16	48.6	15.1	3.96	1.87	.55
18	60.5	18.7	4.93	2.33	.69
20	73.5	22.8	6.00	2.83	.84

Loss of head in meters, due to friction per 100 meters of pipe.

Nominal Pipe Size L/Min.	20mm	25mm	32mm	40mm	50mm
15	3.7	1.15	0.30	0.13	-
20	5.3	1.64	0.43	0.19	-
25	7.1	2.18	0.56	0.27	-
30	13.5	4.13	1.08	0.49	-
35	16.3	5.00	1.31	0.61	-
40	23.5	7.30	1.90	0.88	0.25
45	28.3	8.74	2.31	1.07	0.29
50	34.2	10.6	2.79	1.32	0.38
55	40.7	12.6	3.32	1.56	0.46
60	48.1	14.9	3.92	1.85	0.54
65	55.7	17.3	4.45	2.15	0.63
70	63.8	19.7	5.20	2.46	0.73
75	72.2	22.4	5.89	2.78	0.83

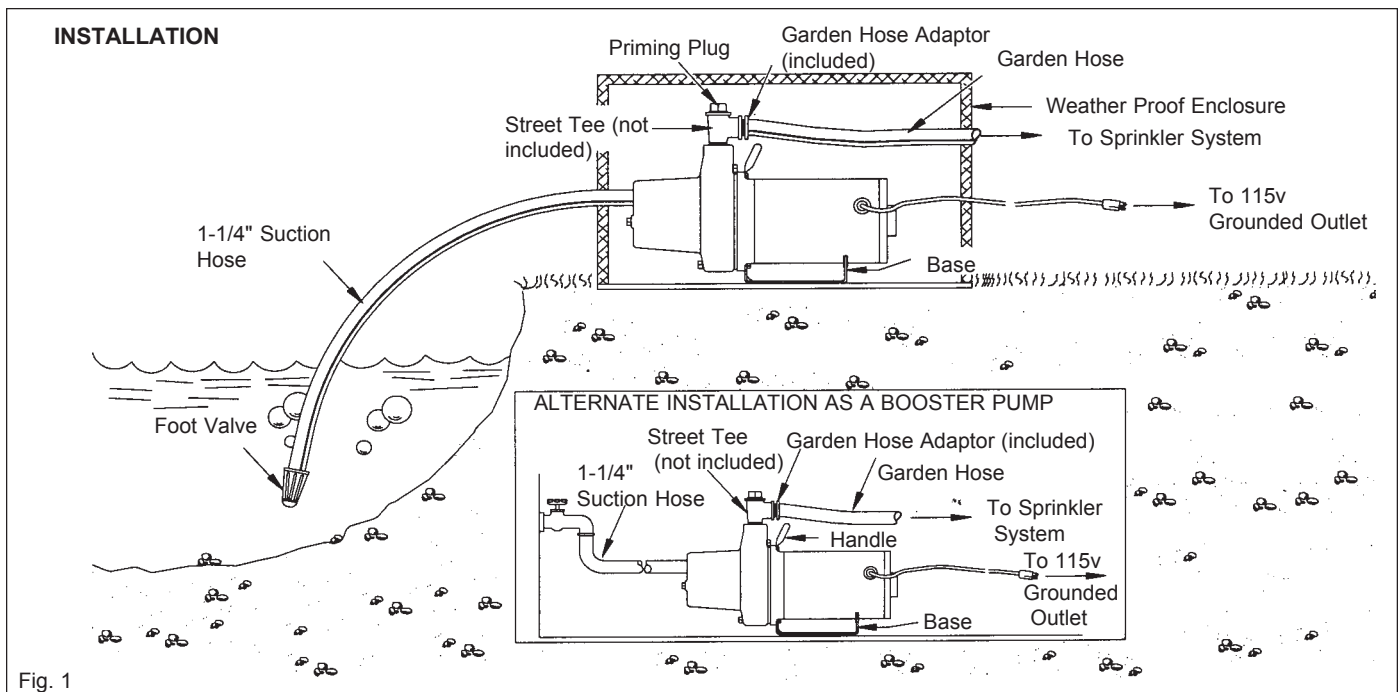

Fig. 1

OPERATION - PRIMING THE PUMP

⚠ WARNING: DO NOT RUN THE PUMP BEFORE PRIMING IT, SINCE THE SEAL AND IMPELLER COULD BE PERMANENTLY DAMAGED.

a) **Priming:** Do not run the pump before priming it, since the seal and impeller could be permanently damaged. Remove the plug from the street tee and pour clean water into the unit until casing and suction line are completely filled. Replace the priming plug and start the motor. If the unit is properly primed, it should pump almost immediately. If not, repeat the priming procedure until all the air has been eliminated from the suction line. If an in-line check valve is used in place of a foot valve, the initial priming time may take 5 to 15 minutes depending on the suction lift, (higher suction lift requires longer priming times). At 10 feet or greater suction lifts, water

should be added to the casing approximately every 3 minutes until primed. If the pump does not prime within 25 minutes, stop the pump and check for suction leaks.

b) **Draining:** Should the unit be subject to freezing, it will be necessary to drain the pump and tank. To do this, shut off the power to the pump at the main electrical service panel. Open a valve in the system to release the pressure. Remove drain and priming plugs from the casing. Allow ample time for system to drain before reinstalling the plugs!

MAINTENANCE

⚠ WARNING - ELECTRICAL PRECAUTIONS

All wiring, electrical connections, and system grounding must comply with the National Electrical Code (NEC) and with any local codes and ordinances. Employ a licensed electrician.

⚠ WARNING - RISK OF ELECTRICAL SHOCK

Before servicing motor operated equipment, shut off the power at the main electrical panel and disconnect the power supply from the motor and the accessories. Use safe working practices during servicing of equipment.

a) **Lubrication:** The pump requires none. Refer to motor manufacturers instructions for motor lubrication.

b) **Cleanout plug:** For applications where clogging is a problem, a 1/4" NPT plug has been provided for access to clean the nozzle/venturi. This plug is located directly below the suction opening in the front of the casing. **IMPORTANT! Before removing the cleanout plug, shut off the power to the pump at the main electrical panel. Open a tap in the water system to release the pressure.**

c) **Replacing Mechanical Seal: (See Fig. 2)**

Disassembly

- 1) Shut off the power to the pump at the main service panel.
- 2) Open a tap in the water system to release the pressure.
- 3) Remove the drain (12) and prime plugs to allow the pump to drain.
- 4) Remove the 4 bolts (1) and remove casing (2).
- 5) Pry the diffuser (4) out of the casing using 2 slotted screwdrivers for leverage.
- 6) Remove cap (5) and insert a screwdriver to prevent the shaft from turning while unscrewing the impeller (6)(GE motors). For A.O. Smith motors, remove rear cover and hold the shaft using a flat wrench inserted from the side, through the opening in the end of the housing. If the impeller cannot be turned by hand, insert a flat object into the impeller vane.
- 7) Slip the rotating seal (7) off the shaft and remove the seal plate (8).
- 8) Remove the ceramic seal seat (9) from the seal plate.

Reassembly

- 1) Clean all the parts thoroughly before assembling.
- 2) Push ceramic seal (9) it into the seal plate using thumbs only. Make sure the smooth surface of the ceramic seat faces outwards.
- 3) Put the seal plate back on the motor.
- 4) Slip on rotating seal (7) to the shaft with the 'carbon' ring towards the ceramic seat.
- 5) Replace the impeller (6) and the diffuser (4).
- 6) Replace the casing (2) making sure that the venturi is properly seated, and that the gasket is not damaged and is in place.
- 7) Reinstall the drain plugs.
- 8) Reconnect the power.
- 9) Prime pump, start, check for leaks.

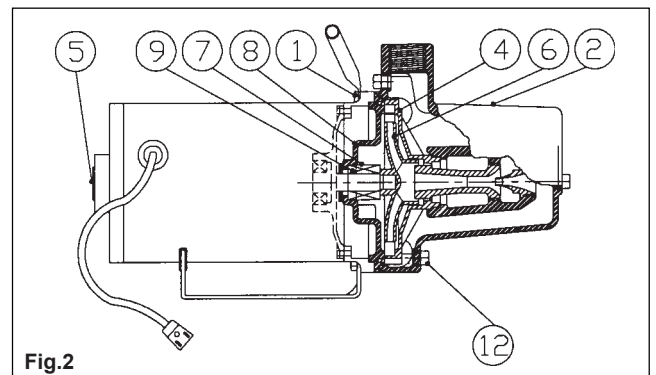

Fig.2

TROUBLES SHOOTING GUIDE

- a) **Motor will not start:**
 - 1) No power due to blown fuses, open switches or loose connections.
- b) **Pump fails to deliver water:**
 - 1) Pump not completely primed.
 - 2) Suction lift is too great.
 - 3) Foot valve is either not submerged, buried in the mud or plugged.
- c) **Pump losses prime:**
 - 1) Air leaks in suction line.
 - 2) Well draw down too far.
 - 3) Faulty foot valve.
- d) **Pump delivers water but not at rated capacity:**
 - 1) Leaks in suction or discharge line.
 - 2) Foot valve, suction line, impeller or nozzle are partially plugged.
 - 3) Suction lift is greater than recommended.
 - 4) Improper impeller rotation or low speed.
 - 5) Motor does not come off starting windings.
 - 6) Low line voltage at motor.

**Toll Free Help Hotline:
1-800-667-1457**

RED LION
51 Burmac Road, P.O. Box 429
Winnipeg, Manitoba, Canada
R3C 3E4

Phone: (204) 786-7921
Fax: (204) 889-9120

www.redlionproducts.com

LIMITED RED LION WARRANTY

For one year from date of purchase, Red Lion will replace or repair for the original purchaser, free of charge, any part or parts, found upon examination by any Red Lion Authorized Service Depot or by the Red Lion factory, to be defective in material or workmanship or both. Equipment and accessories not manufactured by Red Lion are warranted only to the extent of the original manufacturer's warranty. All transportation charges on parts submitted for replacement or repair under this warranty must be borne by the purchaser. For warranty service see your nearest Red Lion Authorized Service Depot. THERE IS NO OTHER EXPRESS WARRANTY. IMPLIED WARRANTIES INCLUDING THOSE OF MERCHANTABILITY AND FITNESS FOR A PARTICULAR PURPOSE ARE LIMITED TO ONE YEAR FROM PURCHASE AND TO THE EXTENT PERMITTED BY LAW. LIABILITY FOR CONSEQUENTIAL DAMAGES UNDER ANY AND ALL WARRANTIES ARE EXCLUDED TO THE EXTENT EXCLUSION IS PERMITTED BY LAW.

This warranty is an addition to any statutory warranty.

RED LION

PRINTED
IN
CANADA